

F2 Twin-flow Pump



4
5

Contents	Page	Chapter
Pump and Line selection	10	2
Specifications	28	
Installation dimensions	29	
Ordering code.....	29	
Standard versions.....	29	
Suction fittings	44	9
Installation and start up	61	12

Specifications

Frame size F2-	42/42	53/53	55/28	70/35
Displacement [cm ³ /rev]				
Port A	43	54	55	69
Port B	41	52	28	36
Max operating pressure [bar]				
continuous	350	350	350	350
intermittent	400	400	400	400
Max shaft speed [rpm]				
(unloaded pump; low pressure)	2550	2550	2550	2550
Max selfpriming speed [rpm]				
Ports A ¹⁾²⁾ and B ¹⁾²⁾ pressurised	1800	1800	1800	1800
Port A ²⁾ unloaded, pressure in port B	2100	2100	2100	2100
Input power [kW]				
Max intermittent ³⁾	100	126	100	126
Max continuous	88	110	88	110
Weight [kg]	19	19	19	19

'Left hand' and 'right hand' end caps

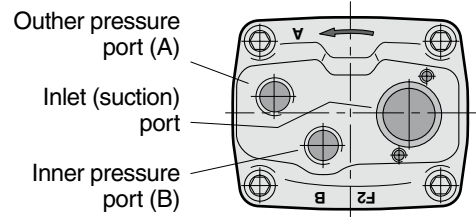

End cap for right hand rotating pump

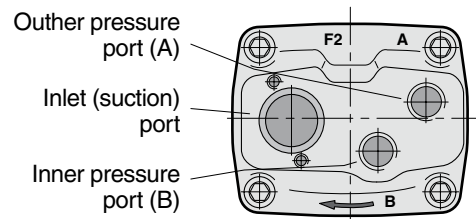

End cap for left hand rotating pump

- Valid with 2 1/2" inlet (suction) line;
 with 2" inlet line: 53/53 and 70/35 max 1 100 rpm
 42/42 and 55/28 max 1400 rpm. (q≈120 l/min)
- Measured at 1.0 bar abs. inlet pressure.
Please note: A lower inlet pressure affects pump performance.
- Max 6 seconds in any one minute.

Flow vs. shaft speed (theoretical)

Pump speed [rpm]	800	1000	1200	1400	1600	1800	1900	2000	2100
F2-53/53 flow [l/min]									
Port A	43	54	65	76	86	97	-	-	-
Port B	42	52	62	73	83	94	99	104	109
Total (ports A + B)	85	106	127	149	169	191	-	-	-
Note: 42/42 values is 80% of 53/53 values									
F2-70/35 flow [l/min]									
Port A	55	69	83	97	110	124	-	-	-
Port B	29	36	43	50	58	65	68	72	76
Total (ports A + B)	84	105	126	147	168	189	-	-	-
Note: 55/28 values is 80% of 70/35 values									

Shaft torque vs. pressure (theoretical)

Pressure [bar]	150	200	250	300	350
F2-53/53 torque [Nm]					
Port A	129	171	214	257	300
Port B	124	165	206	248	289
Total (ports A + B)	253	336	420	505	589
Note: 42/42 values is 80% of 53/53 values					
F2-70/35 torque [Nm]					
Port A	164	219	274	329	383
Port B	86	114	143	171	200
Total (ports A + B)	250	333	417	500	583
Note: 55/28 values is 80% of 70/35 values					

Installation dimensions

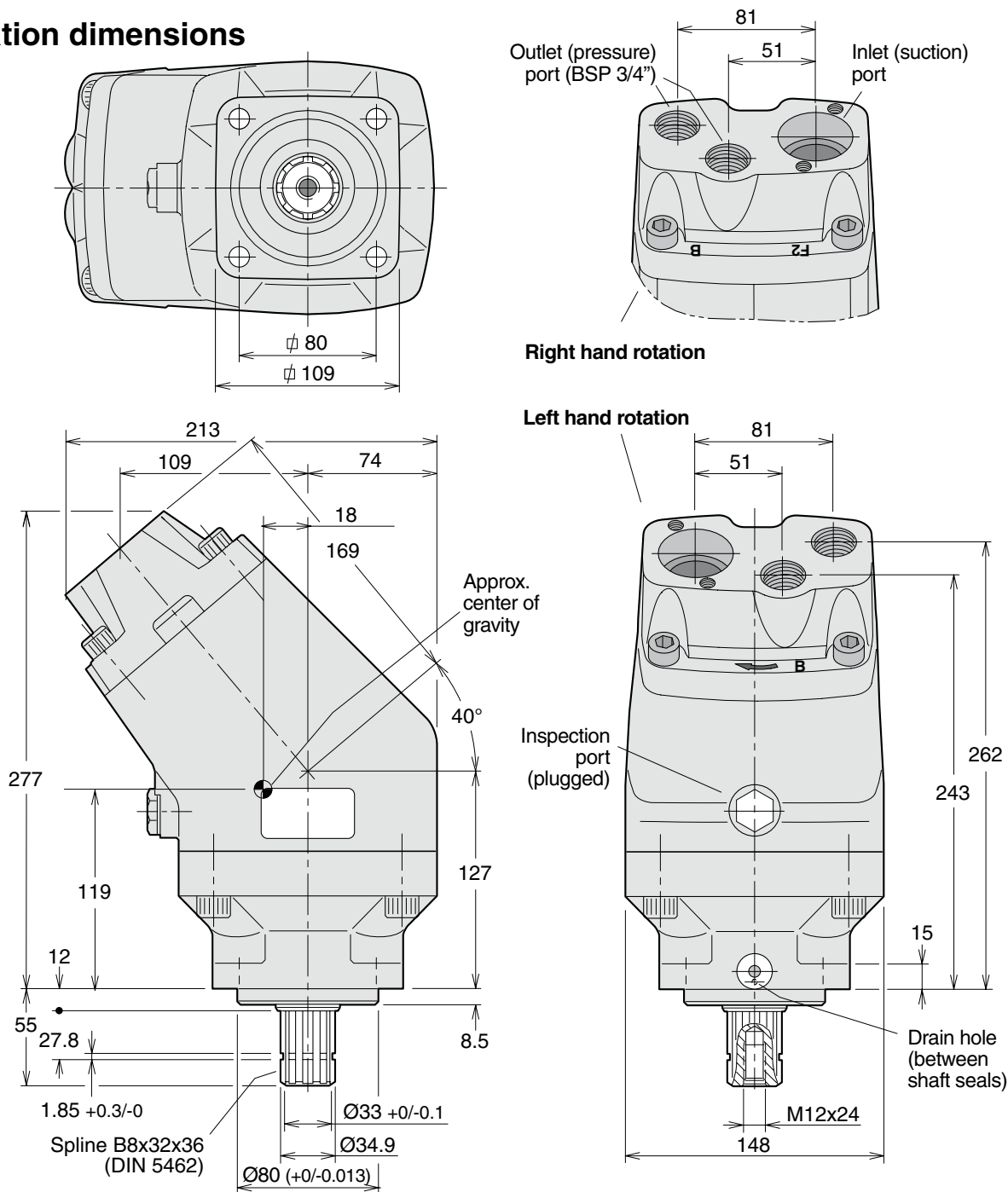

5

Ordering code

Example: **F2 - 53/53 - L**

Frame size [cm³/rev]
42/42
53/53
55/28
70/35

Direction of rotation
L Left hand
R Right hand

Standard versions

Designation	Ordering no.
F2-42/42-R	378 4042
F2-42/42-L	378 4043
F2-53/53-R	378 1453
F2-53/53-L	378 1454
F2-55/28-R	378 4128
F2-55/28-L	378 4129
F2-70/35-R	378 1470
F2-70/35-L	378 1471

NOTE:

- Before start-up, tighten the inspection port plug to 70–100 Nm.
- To change the direction of rotation, **the end cap must be replaced.**

NOTE: The F2 pump **does not** include a suction fitting; it must be ordered separately. See chapter 9.